

INSTRUCTIONS: Line Voltage Precision Spot Fixture

Model: HTK-733

Caution:

Read all instructions before installing. Switch off power before installing or re-lamping.

Overview:

Fixtures are designed for use on "H" series WAC Lighting track. They may also be used on other manufacturer's brand of track (consult factory for compatibility).

Lamping:

1. Use PAR38 (150W max) lamp.
2. Insert the PAR lamp by screwing clockwise into lamp socket.

Accessories:

-NA-

Installing on Track:

1. Note the track head contacts, and the polarity groove running the length of the track.
2. The two contacts should be positioned so that when rotated, they will face the grooved side of the track (this is the side with two flat copper wires running its length).
3. Insert adapter into track slot. Pull downward on the adapter while rotating the adapter 90°.
4. Release the adapter so the locking tab seats in the track slot.
5. Removal is the reverse procedure. Tracks heads may be positioned anywhere along the track length.
6. Not suitable for use on wall mounted track.

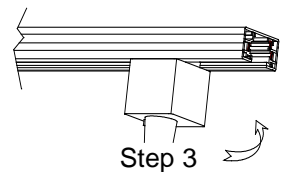
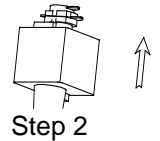
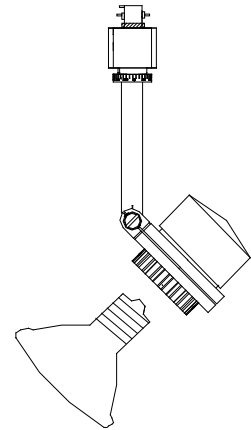

Aiming:

1. Adjust head rotation using the aiming scale below track adaptor.
2. Adjust vertical aiming position by tilting head to desired angle.
3. Lock fixture head into position by tightening the two aiming screws.

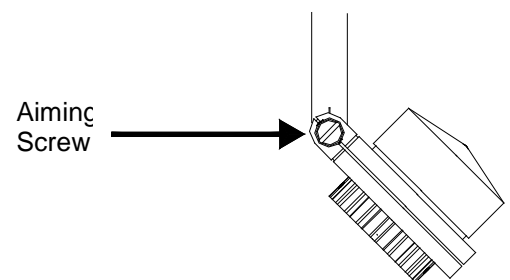

Retain instructions for future reference.

INSTRUCTIONS: Line Voltage Precision Spot Fixture

Model: JTK-733

Caution:

Read all instructions before installing. Switch off power before installing or re-lamping.

Overview:

Fixtures are designed for use on "J" series and "J2" series WAC Lighting track. They may also be used on other manufacturer's brand of track (consult factory for compatibility).

Lamping:

1. Use PAR38 (150W max) lamp.
2. Insert the PAR lamp by screwing clockwise into lamp socket.

Accessories:

-NA-

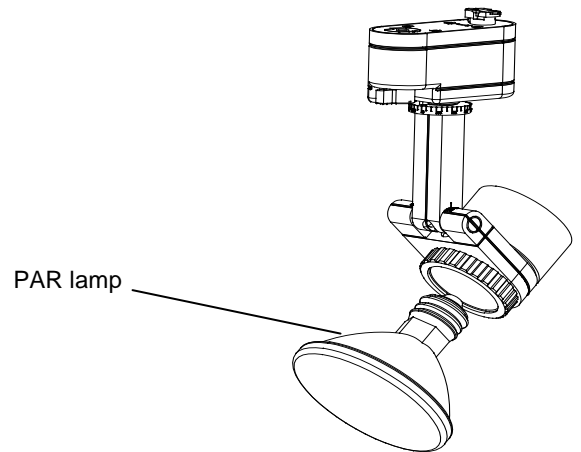

Installing on Track:

1. Note the track has a groove running its length to indicate polarity.
2. Insert adapter into track slot and rotate it 90° the embossed arrow on the adapter should point to the grooved side of the track.
3. Push up and turn the locking tab into the lock position.
4. Removal is the reverse procedure. Track fixtures may be positioned anywhere along the track length.
5. Vertical and horizontal aiming have push lock buttons to secure settings.

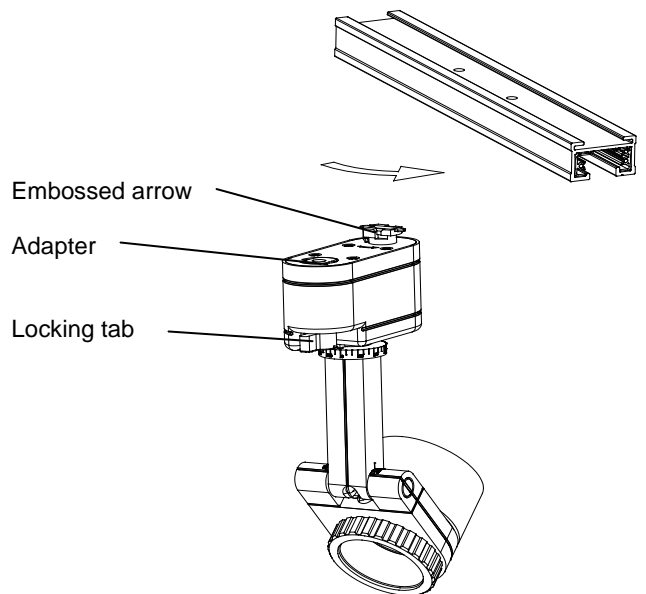

Aiming:

1. Adjust head rotation using the aiming scale below track adaptor.
2. Adjust vertical aiming position by tilting head to desired angle.
3. Lock fixture head into position by tightening the two aiming screws.

Retain instructions for future reference.

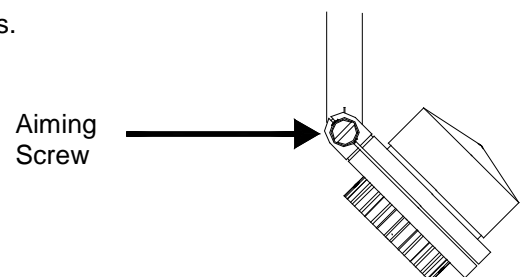

INSTRUCTIONS: Line Voltage Precision Spot Fixture

Model: LTK-733

Caution:

Read all instructions before installing. Switch off power before installing or re-lamping.

Overview:

Fixtures are designed for use on "L" series WAC Lighting track. They may also be used on other manufacturer's brand of track (consult factory for compatibility).

Lamping:

1. Use PAR38 (150W max) lamp.
2. Insert the PAR lamp by screwing clockwise into lamp socket.

Accessories:

-NA-

Installing on Track:

1. Note the track has a ridge running its length to indicate polarity.
2. Note the slant of the locking tab.
3. Insert adaptor into track slot.
4. Rotate adaptor 90° so that the low side of the locking tab faces the ridged side of the track.
5. Make sure the locking tab seats in the track slot.
6. Removal is the reverse procedure. Tracks heads may be positioned anywhere along the track length.

Note: "L" series track accepts only WAC Lighting track heads.

Aiming:

1. Adjust head rotation using the aiming scale below track adaptor.
2. Adjust vertical aiming position by tilting head to desired angle.
3. Lock fixture head into position by tightening the two aiming screws.

Retain instructions for future reference.

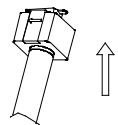
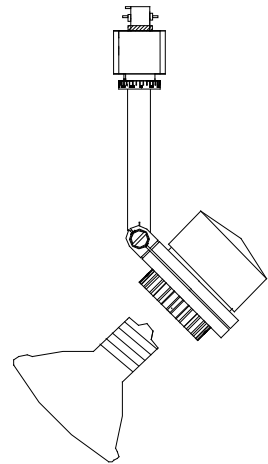

Step 3

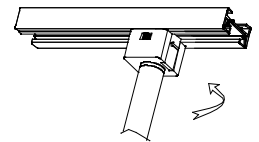

Step 4

