

# INSTRUCTIONS: Installing Flexrail2 HM-164L Fixture

## Safety Instructions:

Fixture is intended for installation in accordance with National Electric Code, local and Federal code specifications. To reduce the risk of fire, electrical shock and injuries to persons:

1. Read all instructions.
2. Turn off power at main switch before installing or modifying the system.
3. Do not attempt to energize anything other than a track light fixture.
4. Fixtures designed for use on WAC Flexrail2 only.

## Installing Fixtures:

Incorporated in the transformer housing are a cover piece and an internal adapter.

1. Loosen the cap ring counter clockwise, to free the top cover. Pull the cover straight off.
2. The internal adapter is constructed in two pieces, with  $\frac{1}{4}$  inch of play between the two. Keep the adapter parts spread so that the metal contacts are recessed.
3. The open end of the adapter is now in the correct position to be pivoted on to the rail.
4. Plant the top end first and pivot the lower end in.
5. Once mounted squeeze the two adapter parts and visually check that the contacts seat in the rail grooves.
6. Replace the top cover and tighten the cap ring.

**Note: Installing the fixture from the reverse side engages the second circuit.**

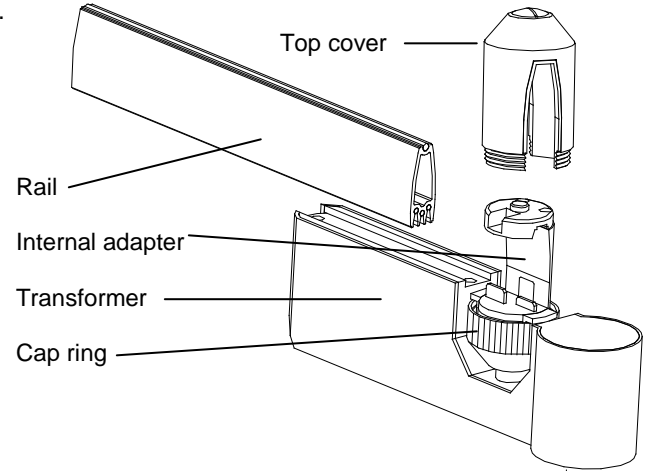

## Lamping:

1. Use 12v MR16 lamp, 75-watt max.
2. Remove the cap ring by twisting counter-clockwise (note: the cap ring contains a clear glass lens).
3. Insert the MR16 lamp by aligning the pins with the holes in the ceramic socket, and pushing straight in.
4. Re-install the cap ring.

## Accessories:

The HM-164L accepts up to two accessories. The clear glass lens supplied in the cap ring may be removed and replaced with an accessory lens and/or louver. Accessory combinations could be the clear lens with honeycomb louver, colored lens with cross baffle louver, etc.

1. Once the cap ring has been removed, remove the compression ring from behind the lens, to free the lens.
2. Place the new lens or louver combination into the recess and re-install the compression ring.

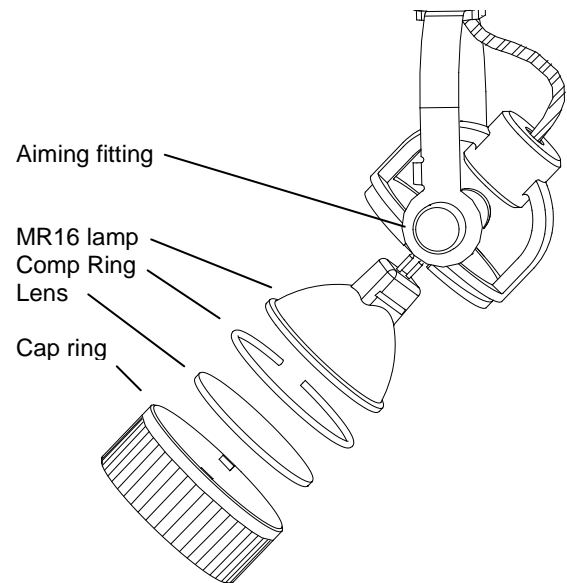

## Aiming:

1. Adjust head rotation using the aiming scale below transformer.
2. Adjust vertical aiming position by tilting head to desired angle.
3. Lock fixture head into position by tightening the two aiming fittings with a small Allen wrench or screwdriver.

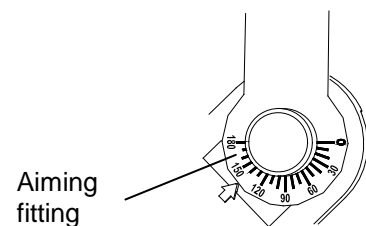

Save instructions for future reference.