

INSTALLATION INSTRUCTION  
**Quick Connect™ Canopy - Early Electric**  
QMP-60ERN

WAC LIGHTING  
Responsible Lighting®

**SAFETY INSTRUCTION**

- Always turn off power at fuse box prior to installation to prevent electrical shock.
- For installation by a qualified electrician.

**OVERVIEW**

QMP-60ERN canopy designed to fit all WAC QUICK CONNECT™ fixtures and pendants(50W max)

The canopy comes with a self-contained electronic transformer that may be dimmed with an electronic low voltage dimmer switch. QMP-60ERN requires the 1" QMP-60-COL collar (included) when installing over a shallow ( 1/2" ) junction box.

**INSTALLATION**

1. Remove the metal ring and separate the canopy from base plate
2. Connect corresponding line volt wires from the junction box to transformer wires (white wire connect to white wire and black wire connect to black wire) with wire nuts supplied. Tuck excess wire into the junction box.
3. Connect ground wire from junction box to the green grounding wire from the base plate.
4. Mount base plate assembly to junction box with two mounting screws supplied.
5. Mount canopy to surface and tighten metal ring to QUICK CONNECT™ fitting
6. Install QUICK CONNECT™ fixture or pendant by inserting QUICK CONNECT™ head post into fitting, and threading clockwise until snug.

Retain instructions for future reference.

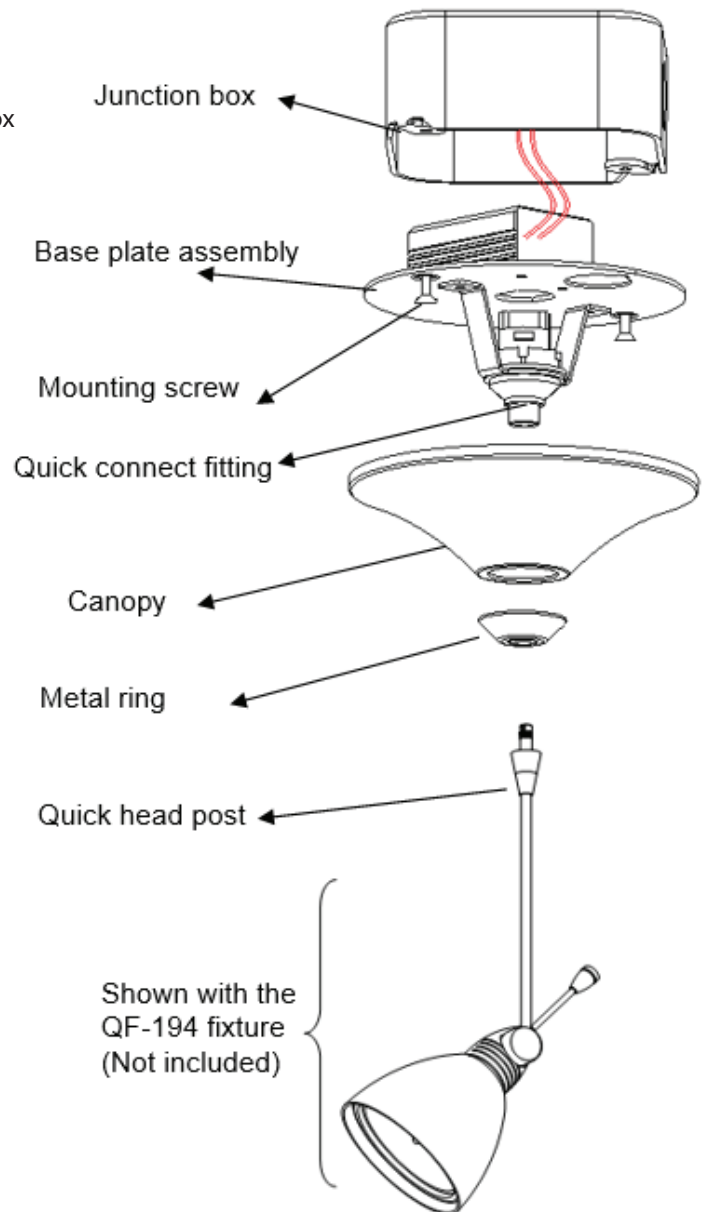

WAC Lighting  
www.waclighting.com  
Phone (800) 526.2588 • Fax (800) 526.2585

Headquarters/Eastern Distribution Center  
44 Harbor Park Drive • Port Washington, NY 11050  
Phone (516) 515.5000 • Fax (516) 515.5050

Western Distribution Center  
1750 Archibald Ave • Ontario, CA 91761  
Phone (800) 526.2588 • Fax (800) 526.2585