

INSTALLATION INSTRUCTION

3" DUO New Construction Housing

HR3D-2015-NICA

WAC LIGHTING
Responsible Lighting®

SAFETY INSTRUCTION

IMPORTANT: NEVER attempt any work without shutting off the electricity.

- Read all instructions before installing.
- System is intended for installation by a qualified electrician in accordance with the National Electrical Code and local regulations.
- Place the wall switch in the "OFF" position.
- Go to the main fuse box, or circuit breaker. Unscrew the fuse(s) or switch "OFF" the circuit breaker switch(es) that control the power to the space that you are working on.

CAUTION:

All parts must be used as indicated in these instructions. Do not substitute any parts, leave parts out, or use any parts that are worn out or broken. Failure to follow this instruction could invalidate the ETL/cETL listing of this fixture.

AVERTISSEMENT

IMPORTANT : COUPEZ L'ÉLECTRICITÉ AVANT TOUTE MANIPULATION.

- Lisez toutes les instructions avant d'installer.
- Système est destiné à être installé par un électricien qualifié en conformité avec le code national de l'électricité et les règlements locaux.
- Placez l'interrupteur mural en position d'arrêt (« OFF »).
- Accédez au panneau central de disjoncteurs ou de fusibles de votre demeure et placez l'interrupteur principal en position d'arrêt (« OFF »).

MISE EN GARDE

Toutes les pièces doivent être utilisées tel qu'il est indiqué dans ces instructions. Ne remplacez pas les pièces, n'en laissez pas de côté et ne les utilisez pas si elles sont usées ou brisées. Le non-respect de ces instructions peut annuler l'homologation ETL/cETL du luminaire.

OVERVIEW:

The housing is New Construction IC rated, and requires a trim for functionality. Check catalog for various trim options.

The housing and trim are recommended to be used with low voltage ELV dimmer.

* Recommended installation distance from the wall is 18 inches

INSTALLATION:

1. Install mounting frame using two hanger bars, (24 1/2" max). Hanger bars are notched on the ends to fit over "T" bars in suspended ceilings. Hanger bars include a captive mounting "screw-nail" for ease of installation (**Fig.1**).
2. Align the bottom of the hanger bar with the bottom of the joist. Secure the "screw-nail" on each end by screwdriver, or by hammer. Slide fixture housing along bar hangers into desired location. Use locking screws to secure (**Fig.2**).
3. Junction box is suitable for branch wiring and has trade size knockouts and integral non-metallic sheathed cable connectors.
4. Remove spring latched junction box cover and connect fixture wires to building wires. Insert each incoming wire into appropriate junction box connector. This fixture features electronic low voltage (ELV) dimming capabilities. To utilize ELV dimming function, connect black wire (line hot) and white (line neutral) in accordance to dimmer specifications. Connect green fixture wire to ground (**as Fig.3**).

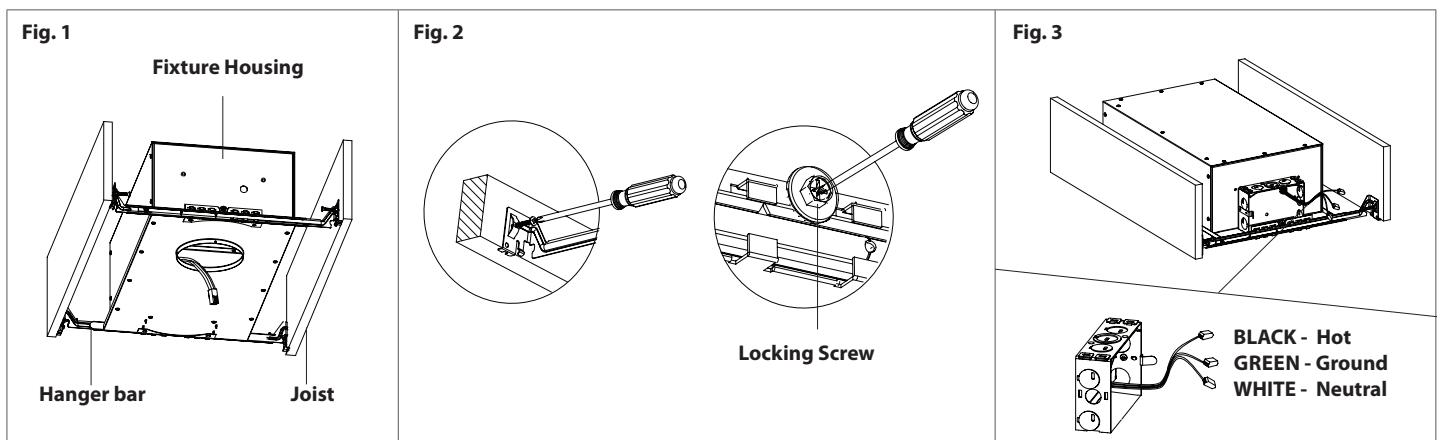

wacighting.com
Phone (800) 526.2588
Fax (800) 526.2585

Headquarters/Eastern Distribution Center
44 Harbor Park Drive
Port Washington, NY 11050

Central Distribution Center
1600 Distribution Ct
Lithia Springs, GA 30122

Western Distribution Center
1750 Archibald Avenue
Ontario, CA 91760

INSTALLATION INSTRUCTION

3" DUO New Construction Housing

HR3D-2015-NICA

WAC LIGHTING
Responsible Lighting®

INSTALLATION: (CONTINUED)

5. Place all wires and connectors back into the wiring box and place the junction box cover back.
6. When installing in drywall, cut a hole 4 5/8" in the drywall. Note: 1 inch maximum ceiling thickness.
7. Raise the trim to the ceiling and connect the power connector. **(Fig.4)**
8. Press the trim clips inward and push the trim assembly up through the cutout hole until the trim ring is flush to the ceiling **(Fig.5 & Fig.6)**

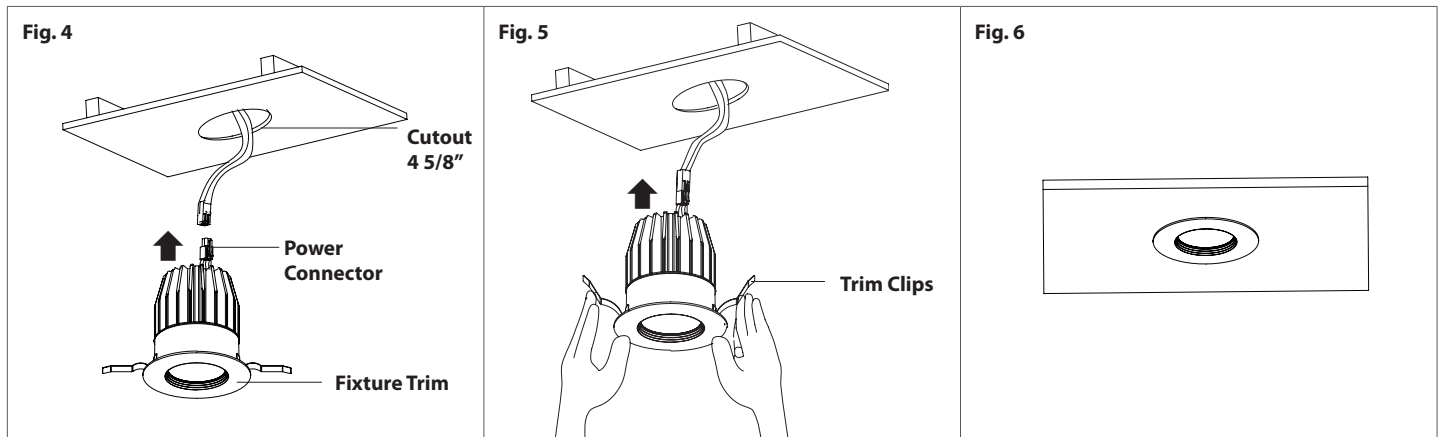

DIMMING COMPATIBILITY

Brand	Model
Lutron	MAELV-600
Lutron	GRX-3103-A-G
Legrand	ADTP703TUM

Brand	Model
Leviton	IPE04
Leviton	DSE06-10Z

waclighting.com
Phone (800) 526.2588
Fax (800) 526.2585

Headquarters/Eastern Distribution Center
44 Harbor Park Drive
Port Washington, NY 11050

Central Distribution Center
1600 Distribution Ct
Lithia Springs, GA 30122

Western Distribution Center
1750 Archibald Avenue
Ontario, CA 91760