

# INSTALLATION INSTRUCTION

## Class II Power Supply

EN-O24100-RB2-T

# WAC LIGHTING

Responsible Lighting®

### CAUTION – TO REDUCE RISK OF FIRE AND ELECTRICAL SHOCK

When installing or using the lighting system, basic safety precautions should always be followed including the following:

- Read all instructions.
- Do not conceal or extend exposed conductors through a building wall.
- To reduce the risk of fire and burns, do not install this lighting system where the exposed bare conductors can be shorted or contact any conductive materials.
- To reduce the risk of overheating and potential fire risk, make sure all connections are tight.
- Do not install any fixture assembly closer than 6 in. from any curtain, or similar combustible material.
- Turn off electrical power before modifying the light system in any way.

<b>Max Load</b>	96W
<b>Min Load</b>	1W
<b>Input Voltage</b>	120-277V AC
<b>Input Current</b>	0.95A
<b>Output Voltage</b>	24 V DC 4A MAX
<b>Ambient Temp</b>	-20°C to 45°C (-4°F to 113°F)

### FEATURES:

- Electronic Short Circuit, Overload, Over Voltage, Over temperature protection with auto-reset.
- Class 2 ,UL listed
- Wet location listed
- 0-10V dimmable

### INSTALLATION:

- The power unit to be installed on the surface of any indoor or outdoor construction with two 5/32"-32screws.
- Power unit must be installed away from heat sources and accessible for service.
- Connect the output female connector of the power supply with the male connector of the InvisiLED outdoor tape or lead wires to form runs. (as **Fig. 1**)
- Next, connect input wires using appropriate junction box and connectors (To utilize 0-10V dimming, wire purple (dim+), grey (dim-), black (line hot), white (line neutral) in accordance to dimmer specifications, green wire connected to ground as shown in **Fig. 2**).

**Fig. 1**

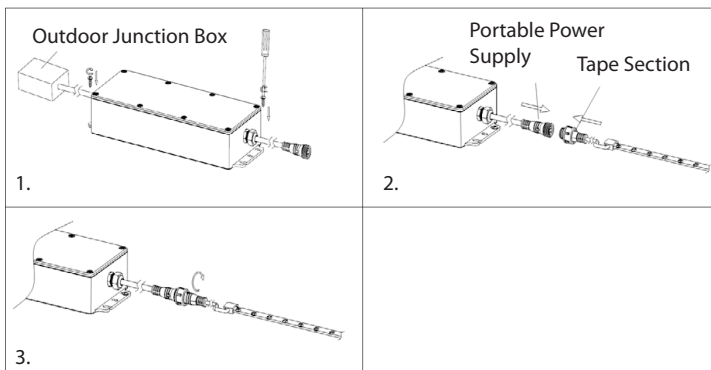

**Fig. 2**

### Input wires

Purple/ (0-10V) Dim +  
Grey/ (0-10V) Dim -  
Black/ Hot  
Green/ Ground  
White/ Neutral

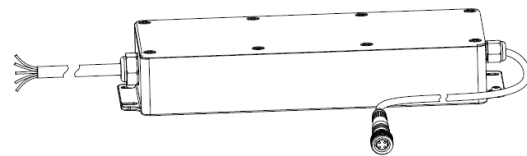

Female output connector

WAC Lighting  
www.waclighting.com  
Phone (800) 526.2588 • Fax (800) 526.2585

Headquarters/Eastern Distribution Center  
44 Harbor Park Drive • Port Washington, NY 11050  
Phone (516) 515.5000 • Fax (516) 515.5050

Western Distribution Center  
1750 Archibald Ave • Ontario, CA 91761  
Phone (800) 526.2588 • Fax (800) 526.2585